

LR-100

4 IN 1 ROUND TURNING SHRINK SLEEVE APPLICATION MACHINE OF TAPES PACKAGING

BENISON



LR-100

LR-100 4 in 1 Round Turning Shrink Sleeve Application Machine of Tapes Packaging

Model Number	UNIT	LR-100
Power		3 ϕ 220V 30A
Machine Dimension	m / m	L 2754mm X W 1370mm X H 2015mm
Applying Tape Size	m / m	OD 50mm~100mm
Core Size	m / m	38mm~55mm
Tape Height	m / m	19mm~60mm

Features

1. Compact working space.
2. Quick size change.
3. Auto feeding & discharging can save much man power.
4. High accuracy of turning orientation
5. 80 set memories of working parameters.
6. The cutting unit is adopted quick change design.

2020.02

- Our packaging specialists will provide you the most efficient and energy-saving packaging system for your products.
- All specifications, design and characteristics shown on this catalogue are subject to change without prior notice.

ALL MACHINES ARE LIABILITY INSURED.

THE M/C CAN BE MADE FOR ANY POWER REQUIREMENT BASING ON ORDER.

MACHINE DIAGRAM

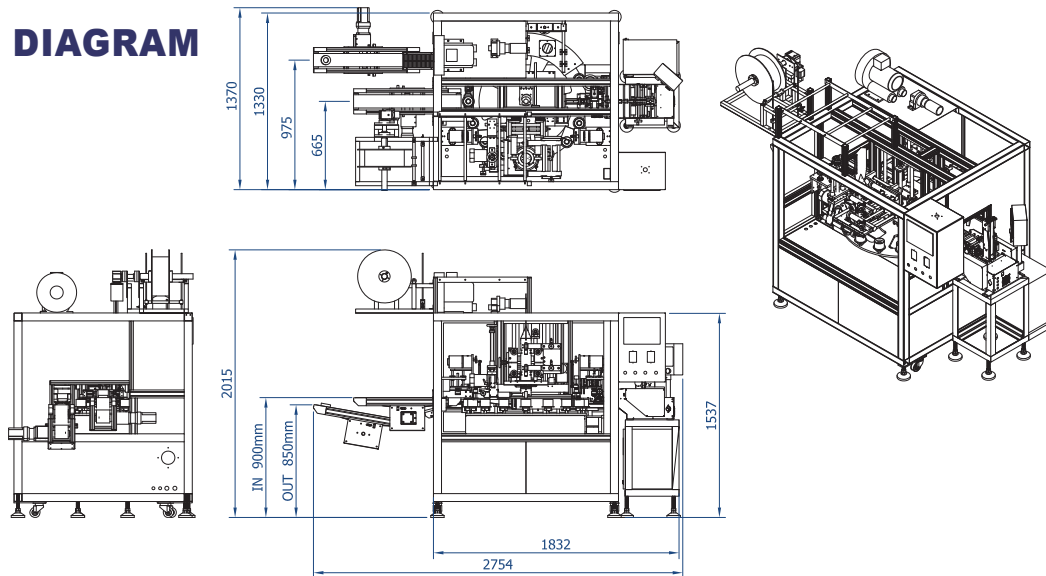

BENISON & CO., LTD.



TAIWAN HEAD OFFICE	:TEL:886-2-2772 5566	FAX:886-2-2772 2382	E-mail:benison@benison.com.tw
TAOYUAN PLANT # 1	:TEL:886-3-322 5531	FAX:886-3-322 8090	E-mail:benison@benison.com.tw
TAOYUAN PLANT # 2	:TEL:886-3-354 7645	FAX:886-3-354 7649	E-mail:benison@benison.com.tw
KAO-HSIUNG PLANT	:TEL:886-7-787 3033	FAX:886-7-787 3042	E-mail:benison@benison.com.tw
PHILIPPINES PLANT	:TEL:63-46-972 2068	FAX:63-46-972 2069	E-mail:sales@benison.ph
CHINA(SHANG-HAI) PLANT	:TEL:86-21-671 00259	FAX:86-21-671 00093	E-mail:benison@benison.asia
THAILAND PLANT	:TEL:66-35-922 086~88	FAX:66-35-922 089	E-mail:benison@benison.co.th

TOLL FREE :

0800-211942 <https://www.benison.com.tw> E-mail : benison@benison.com.tw

All Kind of Shrink Wrapping Film / Color Label / Auto. Wrapping Machines & Sleeving Machines & Cartoning Machine