



EXTEND

EXCSERIES

EXTEND THE PARTNERSHIP

EXC-SERIES

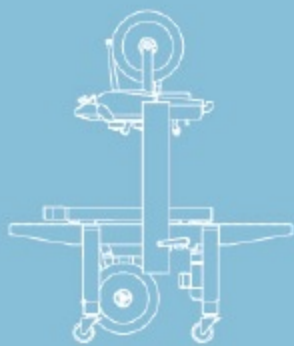

EXC-133SD

EXTEND GREAT INTERNATIONAL CORP.

20F., NO. 309, Sec. 2, TAIWAN BLVD.,
TAICHUNG, TAIWAN, R.O.C.

T 886-4-2326-5568
F 886-4-2326-2268

www.extendgroup.com.tw
extend@extendgroup.com.tw

EXC-133SD



SPECIFICATION

- TAPE WIDTH: 1 1/2", 2"
- BELT SPEED: 23 METERS/MINUTE
- CAPACITY: (L) 120mm - ∞
(W) 110mm-500mm
(H) 120mm-500mm
- POWER SUPPLY: 100/110/220/230/240V, 50/60HZ, 1-PHASE
- POWER CONSUMPTION: 450W

OPTION

- 3" TAPE HEAD
- OUTFEED FLEXIBLE CONVEYOR (EXE-103)



▲UNIQUE TOP SEAT DESIGN

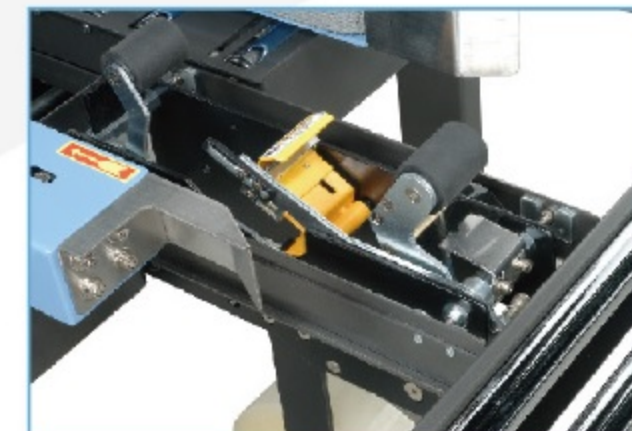

▲EASY TAPE CHANGE

PATENT PENDING

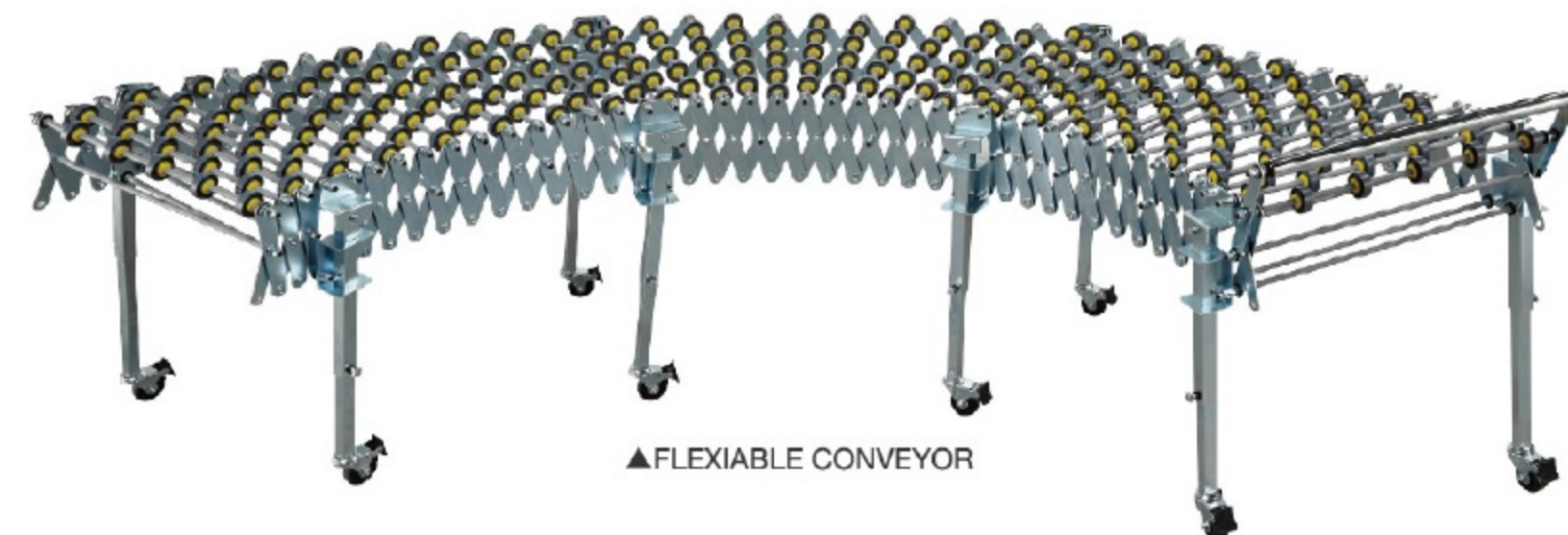
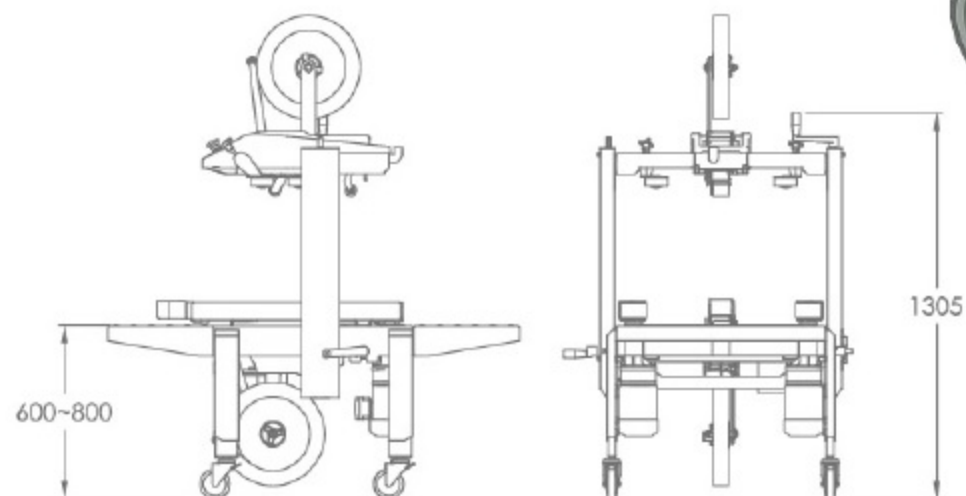
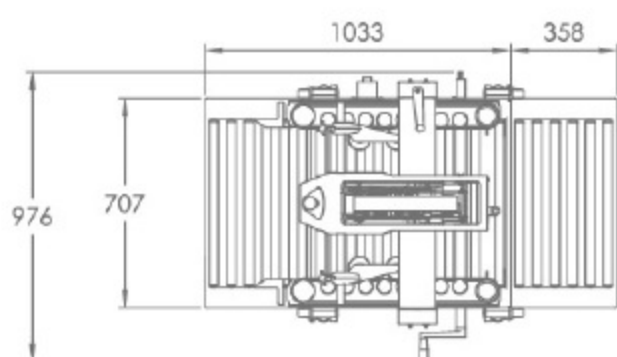

▲FLEXIBLE CONVEYOR